



StairBox

we make stairs...easy

Installation Guide :: Timber stairs



t
s
a
timber staircase association



A Guide to safe stair installation from the BWF Stair Scheme





Contents

		Page
i	Introduction	3
1	Before Installation	4
1.1	General	4
1.2	Checking the delivery	4
1.3	Storage	5
2	Installation	5
2.1	General	5
2.2	Working at height	5
2.3	Temporary fixing of stairs	6
2.4	Clearances	6
2.5	Fixings (anchors)	6
2.6	Assembly	8
2.6.1	Straight flight	8
2.6.1.1	Wall string (inner string)	9
2.6.1.1.a	Notching top of wall string to fit over trimmer	9
2.6.1.1.b	Trimming bottom of wall string	9
2.6.1.2	Outer string	10
2.6.1.2.a	Notching top newel to fit over trimmer	11
2.6.1.2.b	Trimming newel at bottom of outer string	11
2.6.1.2.c	Preparing the outer handrail	12
2.6.2	Half landings	13
2.6.3	Quarter landings	13
2.6.4	Winder flight	14
2.6.4.1	Top and bottom winders	14
2.6.4.2	Middle winders	15
2.6.4.3	6 winder turns	16
2.6.5	Balustrade	17

Note: Whilst every effort has been made to ensure the accuracy of advice given, the BWF and StairBox cannot accept liability for loss or damage arising from the use of the information supplied in this publication.

i :: Introduction



The BWF Stair Scheme Installation Guide is intended to provide general information about installing timber staircases, focusing on key areas to ensure that the stairs are safe to use and not compromised by poor practice. The members of the BWF Stair Scheme design and manufacture their stairs so that they will support the necessary loads in both the flights and the balustrades, but poor installation can cause the stability of the stair to be reduced, possibly leading to premature failure of components and ultimately the collapse of the stair.

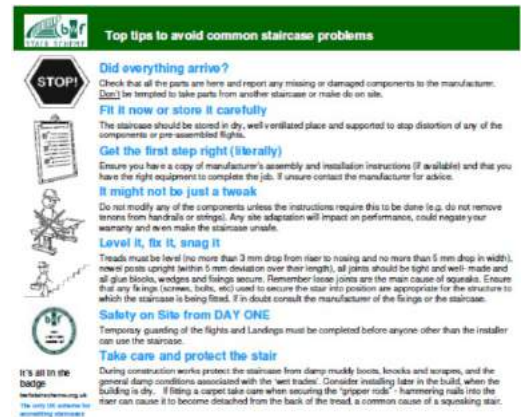

The installation process itself has inherent risks and care should be taken to adequately support the stair until all the necessary fixings to the surrounding structure are in place. No stair should be used for access until its full load bearing capacity has been achieved and it is securely fixed in place.

If you are looking for simple factsheets and toolbox talks to help project the essence of this guide –“Top Ten Tips to avoid common staircase problems” is available via www.bwfstairscheme.org.uk as a fact sheet and electronic presentation.

It's All in The Badge

The BWF Stair Scheme is the only accreditation and certification scheme of its kind in the UK. Ranging from domestic, common and fire protected common stairs, the standard expected of the manufacturers for their stairs is high with a drive to improve quality and safety in use, supported by an effective factory production control system and adherence to the core principles and values laid down in the BWF Code of Conduct.

All companies within the scheme are regularly audited to ensure their products and their production meet these high standards, and the new third-party certification for fire protected common stairs, supported by The Loss Prevention Certification Board (LPCB) is opening up new markets for timber stairs. The scheme is managed by the BWF, and includes manufacturers, as well as approved suppliers, who play an important part in maintaining these high standards.

Whilst the BWF Stair Scheme does not accredit installation, guidance is available on the installation of staircases.





1 :: Before Installation

1.1 General

To ensure the minimum time required for site storage plan the delivery of the stair to be close to the time when it will be installed.

Take care when handling stair components, particularly long flights, as these can be heavy and may need an assisted lift.

1.2 Checking the delivery

When the stair is delivered to site check the delivery against manufacturer's documentation / CAD drawings:

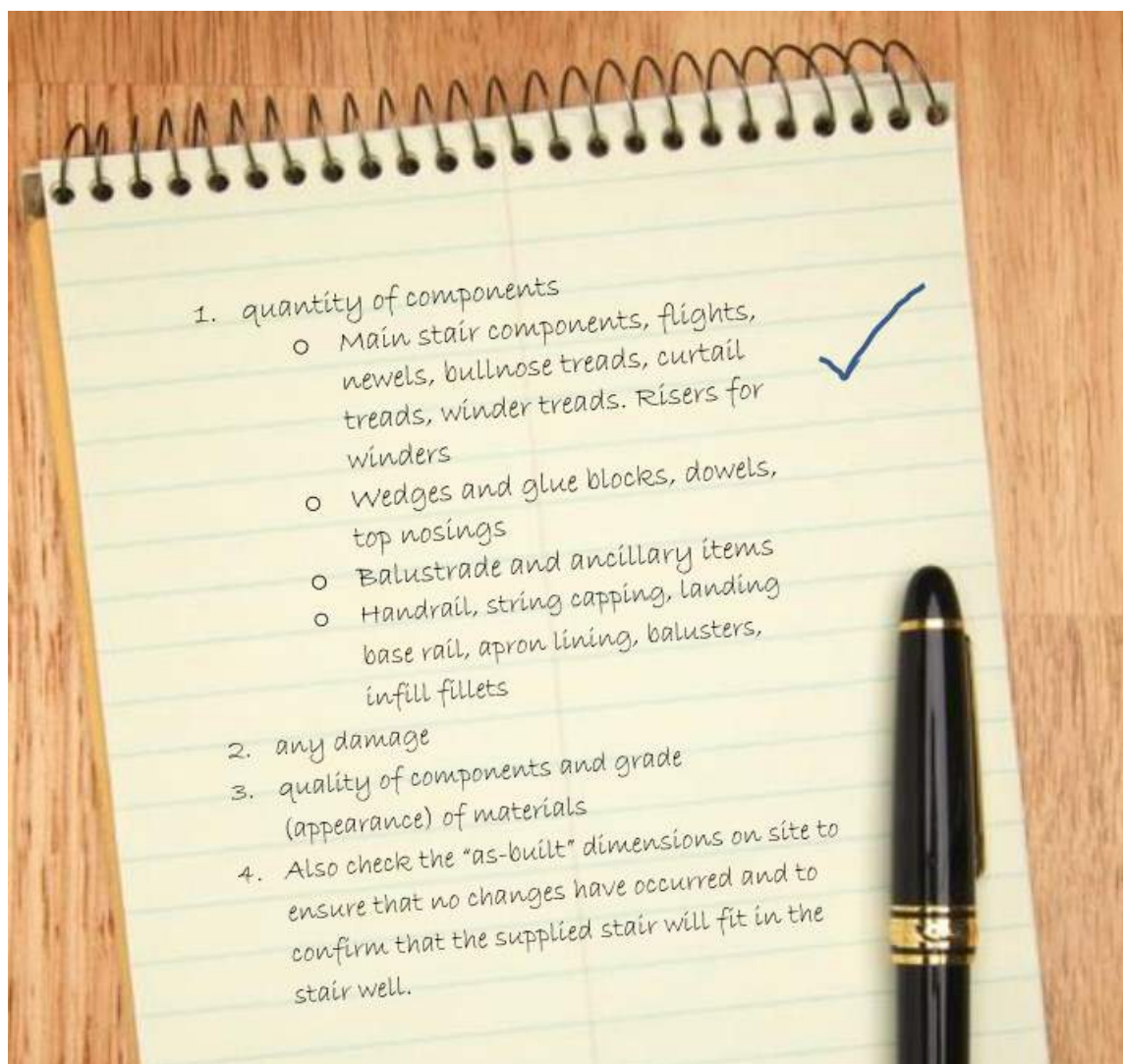

1.3 Storage

- * Ideally arrange for the staircase to be delivered when you are ready to install it.
- * If necessary stair components should be stored in clean, well ventilated conditions, protected from damp and direct sunlight.
- * Long items should be kept flat on bearers.
- * If components are delivered for more than one stair, store the parts for each stair separately or mark each item so that they can be easily identified. Do not mix stair parts when installing as stairs will usually be made to suit a particular stairwell arrangement.
- * If storing stairs in the building take care not to overload any part of the structure by stacking too many parts together. On upper floors store components near to walls on which the floor joists bear, rather than in the centre of rooms.



2 :: Installation

2.1 General

When installing a stair it is usual to start from the top and work down. There may need to be some preparation of joints and trimming to size of components, where required, before the components are fixed in position and this should be checked prior to starting the installation.

Wall strings, newels and landings will need to be fixed to the supporting structure. Consideration should be given to the type of fixings used to ensure that they provide a suitable level of support and that they are appropriate for the timber, block or other material to which the stair is being fixed.

All fixing points should be prepared with clearance holes (through the piece being secured) and pilot holes (into the structure being secured to). Never force a fixing into any material, unless the fixing is intended for that purpose, as this will cause splitting of timber and will weaken the joint. Care when handling should be taken to protect the delicate birdsmouth joint.

2.2 Working at height

Care should be taken when installing a stair as the nature of the work will present a risk of falling.

Full protection to the outside of any stair will not be afforded until the complete guarding system, balusters or infill panels and handrails have been fixed in place.

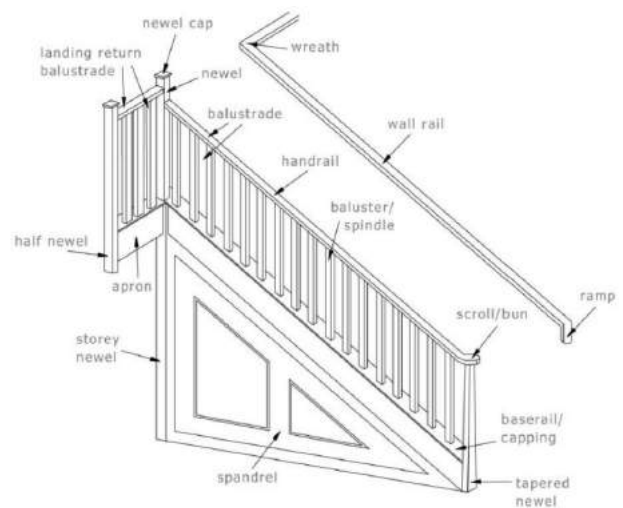

As an alternative, a suitably accredited temporary guarding system may be used until the final guarding is in place. (Accredited to EN 13374:2004, Temporary edge protection systems. Product specification. Test Methods). The Health and Safety Executive publish advice on working at height on their website at:

<http://www.hse.gov.uk/construction/safetytopics/workingatheight.htm>

2.3 Temporary fixing of stairs

A staircase will not be able to provide its full support until it is installed completely with all fixings in place. Until this is achieved there is a chance that elements of the stair could become dislodged from their positions, for example, a newel could fall from its location over a trimmer, or a missing fixing or anchor, could cause unexpected loading to a part of the stair leading to failure.



During the installation process it may be necessary for the installer to use the stair, but this should only be undertaken with caution having ensured that temporary supports, such as a block at the base of the stair to prevent slipping, or temporary propping, is in place before the installer applies any load to the stair. At this time, no guarding will have been fitted so the installer should also consider any risks associated with falling from the stair.

Before a staircase is used for access between storeys the trunk should be fully installed and capable of supporting its intended loads with all fixings, packers and supports in place. Any edges where there is a risk of falling should be protected by the supplied guarding or balustrade or by adequate temporary guarding. (Temporary guarding should be accredited to EN 13374:2004, Temporary edge protection systems. Product specification. Test Methods)

2.4 Clearances

The finished size of the stair should not be equal to the sizes measured on site, as this will not afford any flexibility while installing the stair and may not permit parts of the flight to be manoeuvred into position. Consideration should also be given to any finishes that are yet to be applied to the walls of the stair opening, such as, dry lining or plastering. The finished size of a stair can be up to 40 mm less than the “tight” sizes measured on site but any clearances between the stair and any fixing points should be packed out prior to fixing.

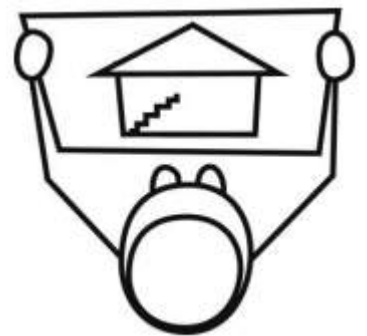

2.5 Wall string fixings

Structural screws, which are CE marked to EN 14592, should be used to fix wall strings to timber stud walls or masonry walls. The screws should have a nominal diameter of 5mm (10 gauge), and should either be of the self-drilling type, or should be installed in predrilled holes. The length of the screw should be chosen to achieve a minimum penetration of 50mm into the timber stud/nogging or into the masonry wall, and 50mm long wall plugs should be used in masonry walls (see Figure 1a).

Figure 1b

Fixing Centres for private stairs with gaps between string and wall of less than 40 mm

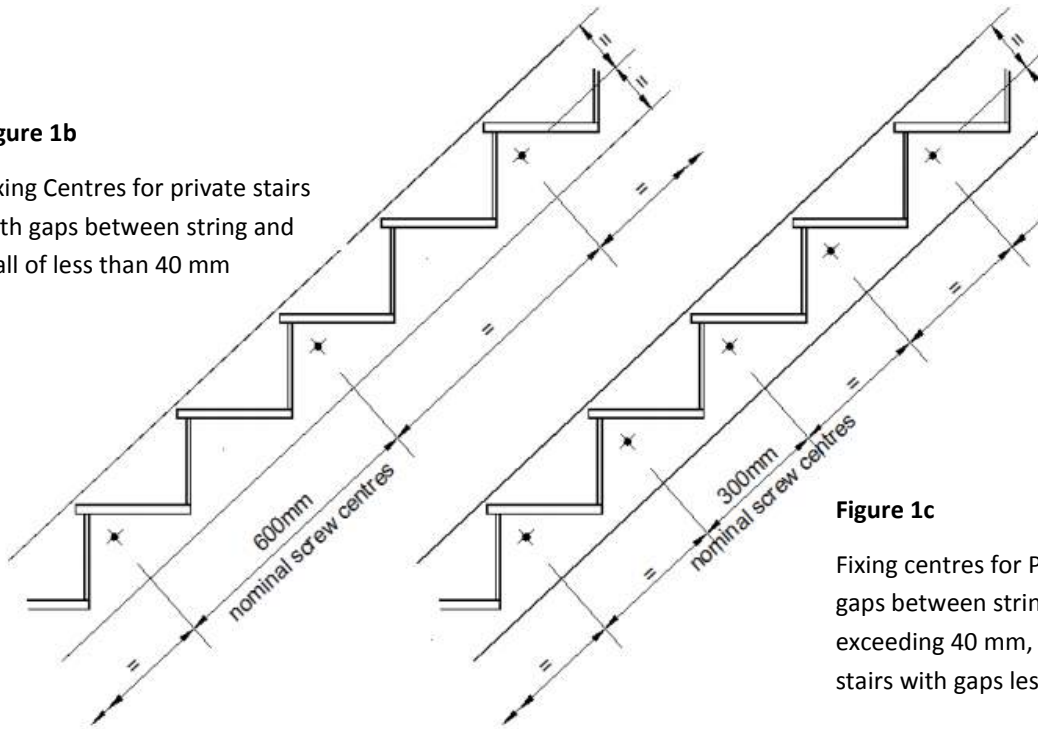

Figure 1c

Fixing centres for Private stairs with gaps between string and wall exceeding 40 mm, or General Access stairs with gaps less than 40 mm.

To facilitate fixing into timber stud walls, timber noggings should be provided between the vertical timber studs which follow the intended line of the fixings. These timber noggings should be a minimum of 45 mm wide x 72 mm deep, and be fixed to the timber studs at each end using 2No 75 mm long screws inserted perpendicular to the nogging (see Figure 1d).

Alternatively, additional studs may be provided at 300 mm c/c to enable direct fixing into studs and avoid the need to insert noggings.

Figure 1d

Addition of timber nogging to support fixing of stair string to stud wall construction.

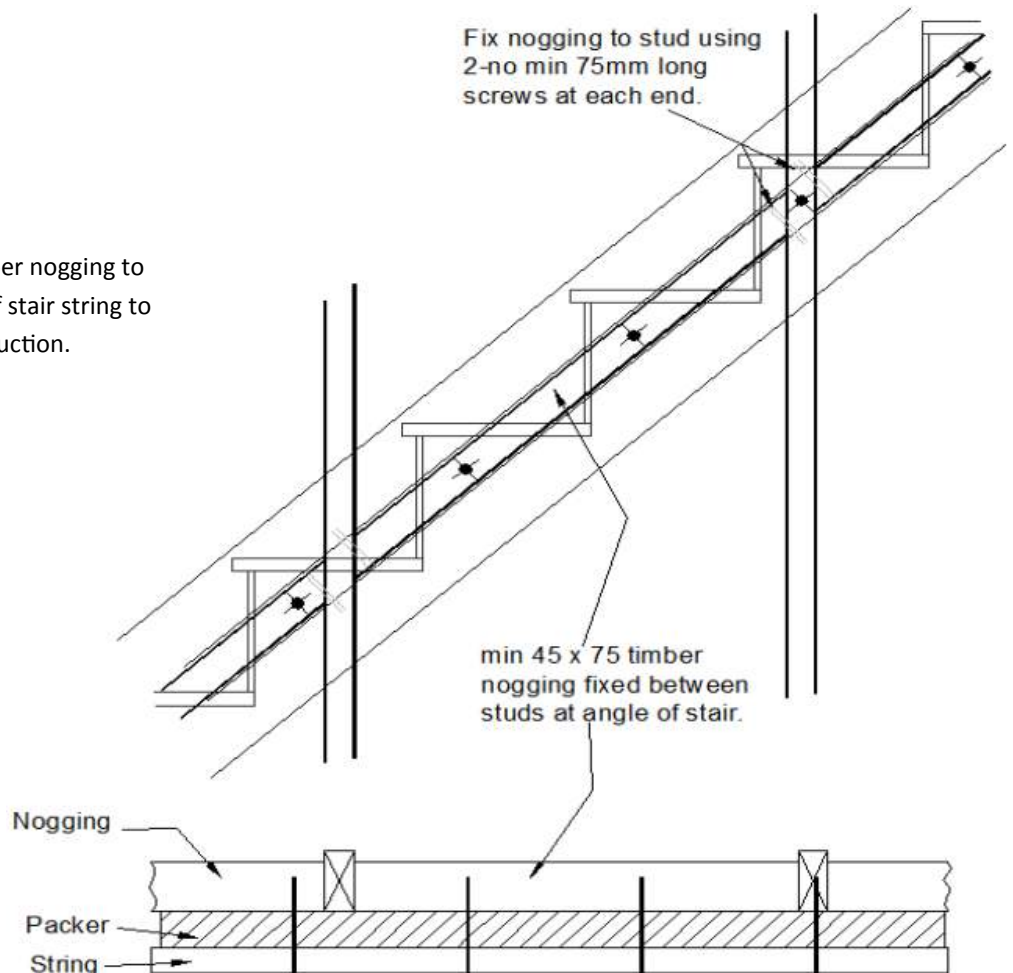

2.6 Assembly

2.6.1 Straight flight

You would usually order your staircase factory assembled, however where access is tight you may require the stairs in kit form. This guide will explain how to assemble your staircase on site.

STEP #1

Start by dry wedging a tread and riser at each end of the stair run, now place the other string on top dry wedging this (look at the plan and ensure the treads are in the correct housings). You can now lay the staircase flat, allowing you to slot all of the other treads and risers into their housings. If your staircase has newel posts be sure to put the notched treads in the correct housings (look at your plan drawing), notched treads should be numbered.



STEP #2

The next step is to board and clamp the staircase before we wedge all of the treads and risers. To do this put some loose timber boards / packers either side of the staircase stringers to prevent marking from clamping, now clamp over the width. Be sure your staircase is square before tightening up all clamps, to do this place one edge of your square against the stringer and let the other run down the riser (you will need to make sure the tread and riser sit fully down in the stringer trenching before checking for square). Be sure not to over tighten the clamps.

STEP #3

Remove your dry wedges, apply a generous amount of glue to the whole set of wedges and slot them in behind the treads. Drive in the wedges making sure all of the treads are completely down in their housings, now do the same with the risers.

STEP #4

This stage is very important, and if done correctly your staircase should be forever squeak free!

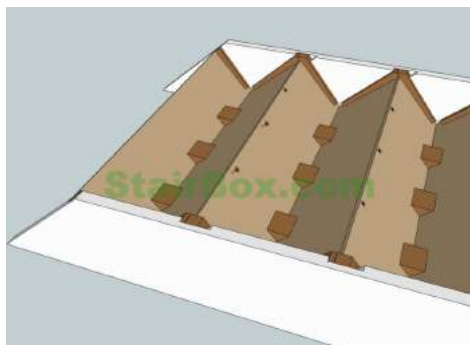

The first step is to fix the risers to the treads, using a chisel prize open a slight gap between the tread and riser, next run a small bead of glue (we recommend PU woodweld or similar) along the back of the tread where the riser will meet. Beware not to over glue this joint, especially if the flight is not being carpeted as the glue can be difficult to remove from the face of your staircase - its best to run the bead of glue towards the under edge of the stair.

You are now ready to screw the riser to the tread, if your treads and risers are MDF we recommend 40mm screws, on timber 30mm should be ample to fix a 10mm riser. Use 3-4 screws in the pre-drilled holes, be careful not to over tighten or let the screws spin. If screwing into a hardwood tread you will need to drill a pilot hole approximately 2-3mm in diameter.

The next step is to glue the angle blocks in place with generous amounts of glue, it is very important that these are fixed properly and the glue is allowed to set before use.

2.6.1.1 Wall string (inner string)

2.6.1.1.a Notching top of wall string to fit over trimmer

Cut the underside of the string so that the top face of the top nosing piece will sit flush with the surface of the flooring and the back of the top riser sits against the trimmer but a clearance of up to 5 mm can be accepted. Cut the upper side of the string so that it aligns with the skirting.

Figure 2—Top of wall string

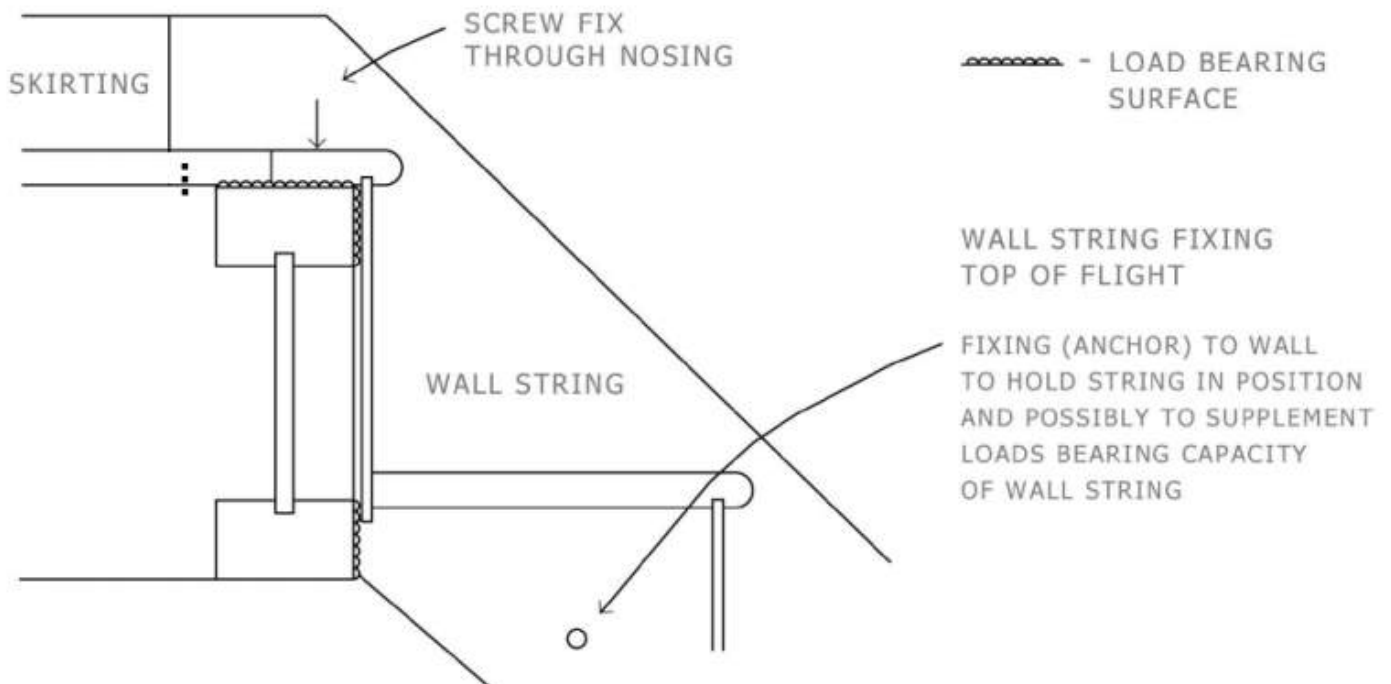

2.6.1.1.b Trimming bottom of wall string

On a StairBox staircase the bottom wall string is already cut correctly to suit your floor height.

However it can be trimmed slightly to suit any discrepancies, for example, if the designed total rise is 2600 mm for 13 individual rises of 200 mm but the floor to floor measurement taken on site is 2597 mm then the bottom rise can be trimmed to 197 mm ($12 \times 200 \text{ mm} + 197 \text{ mm} = 2597 \text{ mm}$)

In the same way the bottom riser can be packed up slightly. Any difference, however, should be no more than $\pm 5 \text{ mm}$. If the bottom rise varies by more than this when compared to the designed rise of the other steps a trip hazard would be created.

Figure 3—Bottom of wall string to floor

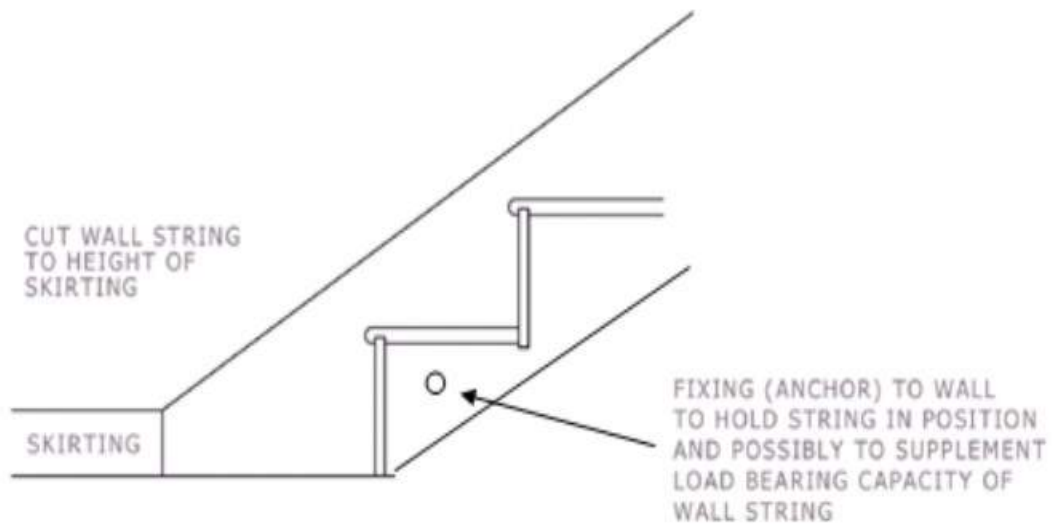
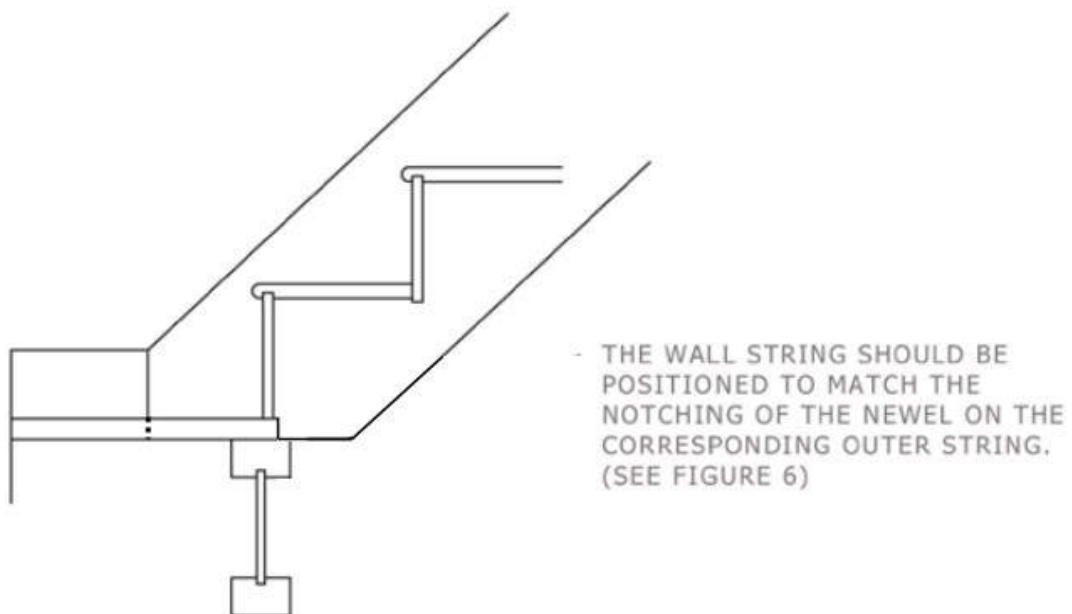

Figure 4 – Bottom of wall string to trimmer



2.6.1.2 Outer String

The outer string is jointed at the top and bottom ends into newel posts (or newel bases). The joint used by StairBox is a mortise and tenon joint, secured into place using two m8 bolts through the opposing face. You may wish to try the post onto the tenon 'dry' to ensure you are happy with how it fits onto the staircase, and onto the trimmer joist, however be sure to apply glue to the joint before final fixing.

Before fixing, the newels to the outer string will need to be prepared as follows;

2.6.1.2.a Notching top newel to fit over trimmer

The back face of the newel will need to be notched to receive the trimmer. The notching should position the top of the top nosing flush with the surface of the floor and the back face of the top riser with the same clearance as created by the cutting of the wall string.

Note: Notch the newel to the depth of the trimmer, but do not fit the newel over the flooring. Remove the flooring (i.e. chipboard) to accommodate the wall string, newel and top nosing.

Figure 5 – Top of outer string

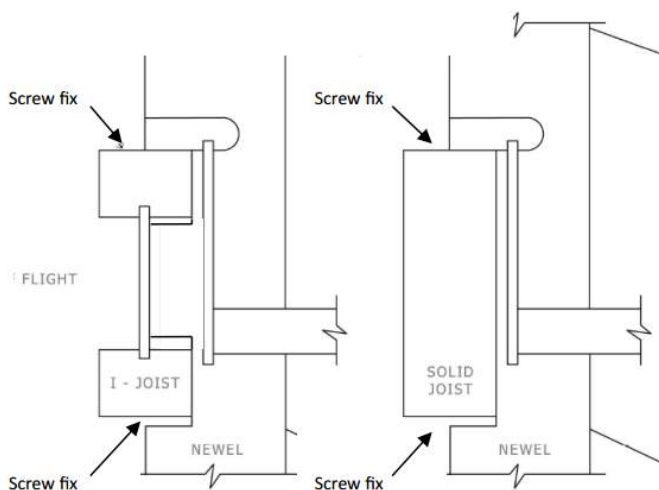

Fixings are to be structural screws, which are CE marked to EN 14592, 6mm x 90mm

2.6.1.2.b Trimming newel at bottom of outer string

Before fixing the bottom newel to the outer string the bottom end of the newel may need to be trimmed to the correct total rise or floor to floor site measurement. (refer back to the section on cutting the wall string).

Note: the bottom newel may not be at the bottom of the flight. There could be up to two additional steps to be fitted, for example, a bullnose step, or a bullnose step together with a curtail step.

Figure 6 – Bottom newel post on trimmer

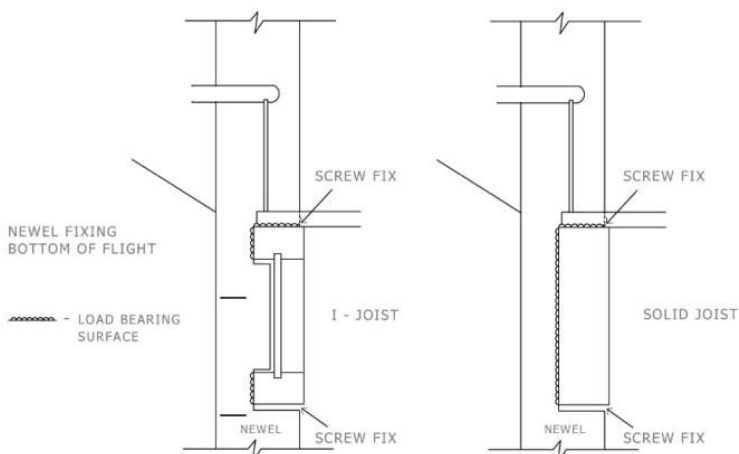

Fixings are to be structural screws, which are CE marked to EN 14592, 6mm x 90mm

Figure 7 – Bottom treads - side view

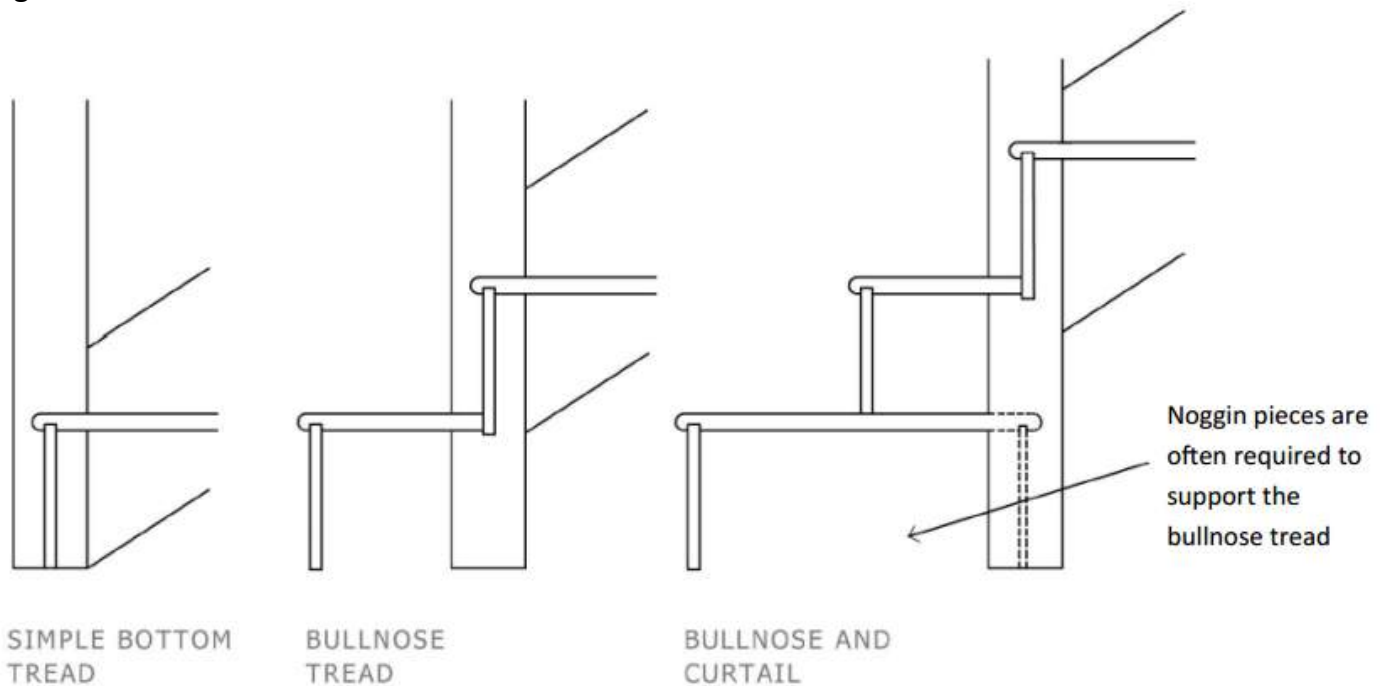
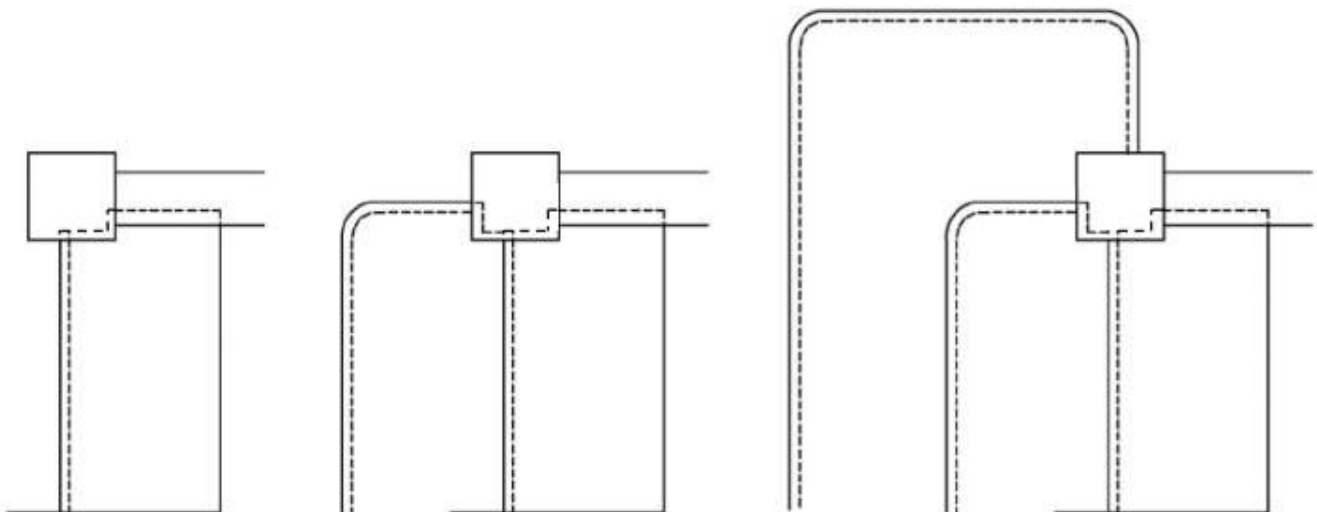

Figure 8 – Bottom treads - plan view



2.6.1.2.c Preparing the outer handrail

Handrails are used to support a person using the stairs in the event of a trip or a slip and to provide assistance to people with impaired movement. Handrails can also form the top of a balustrade or “safety barrier” protecting users of the stair from falling. It is essential that handrails are fixed securely.

StairBox handrails are usually pre-cut with mechanical fixings, handrails are to be fitted after the staircase has been installed using the bolts provided.

Note: A handrail on its own cannot act as a safety barrier. Full protection from falling will only be afforded by the completed guarding system or a suitably accredited temporary guarding system.

2.6.2 Half Landings

Landing supports and landing boards are not supplied by StairBox. (Landing boards may be supplied if the staircase is in hardwood).

Half landings will need to support the same loads as the floors of the property into which the stair is being installed.

The trimmer onto which the top of one flight and the bottom of the second flight will bear will need to support the loads imposed when the flights are being used.

Unless specified otherwise half landings should use the following minimum joist sizes up to a maximum landing size 1.2 m x 2.6 m.

Type of stair	Joists at walls and at 600mm centers max (mm)	Trimmer between walls (mm)
Domestic	47 x 147	2 x 47 x 195
Common	47 x 195	2 x 47 x 225

Trimmers should be let into the walls, but not into cavities, for support or supported by joist hangers. Joists can be screwed or bolted to walls. Where trimmers are doubled, the two sections should be screwed or bolted together to avoid slippage and to share the imposed loads from the flights.

The top of the lower flight should be prepared as if the landing was an upper floor (see Figure 4). The bottom of the upper flight should be prepared as if the landing was the lower floor with the newel finishing in-line with the bottom riser (see Figure 5).

The flights should bear on the trimmer and not on the boarding used to form the surface of the landing. This will allow the boarding to be replaced if it becomes damaged. To maintain the rise of the bottom step is consistent with the rest of the flight, an allowance equal to the thickness of the boarding of the landing will need to be made when cutting the string or newel and bottom riser for height.

2.6.3 Quarter landing

Quarter landings will need to be able to support the same loads as the floors of the property into which the stair is being installed.

The newel forming the corner of the stair where the outer string turns through 90 degrees will need to be notched to receive and support the outer corner of the landing.

If the newel is to be notched, it will need to act as both a “top” and “bottom” newel for the outer strings and be prepared in two directions accordingly.

The joist sizes should be as given above for half landings in Table 2. (Trimmers are not required for quarter landings.)

2.6.4 Winder flight

Where the winder flight is at the top of the stair, the newel and wall string will need to be prepared to fit over the trimmer in a similar manner to the top of a straight flight. If the winder flight forms the bottom of the stair, the newel and wall string will need to be prepared in a similar manner to the bottom of a straight flight.

It is easiest to assemble the winder turn with the staircase lay on its wall stringer (as shown in the diagrams). However please ensure you have sufficient space to manoeuvre the stair into place with the turn assembled. If this is not possible you must build the turns up in situ, where possible start from the top and work down. You will require 1-2 people to help lift your staircase into place, you may wish to clamp a prop to hold the staircase while fixing. If you are building your turn up before fitting, ensure the floor you are working on is flat and level.

We recommend dry assembling the whole winder turn before you apply any glue so you are confident with how everything fits in place.

This guide below will run through how to build up a winder turn before fitting the staircase. Due to site limitations, it is not always possible to assemble a winder flight as described below.

Fitting a top or bottom winder

STEP #1

With your newel post fitted, locate the first winder step which follows on from the straight run of steps. Slide the winder fully into the wall stringer and newel post housing, the winder should fit perfectly in the housing with the back of the tread in line with the above riser trenching **do not trim or modify** any treads, these are cut accurately on a CNC machine, if it doesn't fit you may have the tread in the wrong place. If you have a problem, please call us.

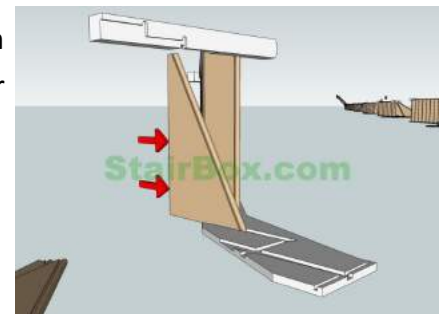

Once you are happy the winder fits into its housing, apply a bead of glue to the newel post housing and to one of the larger (approx 300mm long) winder wedges and drive it into the trenching under the tread using a hammer, ensure the winder tread remains fully seated within the stringer housing (it may sit 1-2mm shy from the bottom of the newel post housing, you must ensure the newel post remains at 90° to the tread!). Next, use a screw secure the newel post end of the winder tread, you will need to drill and pilot drill where appropriate.

STEP #2

Slide the next winder (kite shaped) fully into the stringer (ensure you have the correct one as they will be different). Slot the loose stringer into place to ensure the corner tread fits into this adjacent stringer, using a square make sure the stringers are 90° to each other. Now you are happy with how the tread fits we can secure it into place.

***on a bottom winder** If you are assembling the winder box before fitting the staircase you may find it easiest to fix the corner winder into the housing on loose stringer first of all as its difficult to drive a wedge in once this is fitted.

Glue the stringer tenon into the mortice slot, you can screw through the back of the upper stringer to hold this in place.

Using the same method as before fix the final winder (and bullnose step) into place, the next step is fitting your risers.

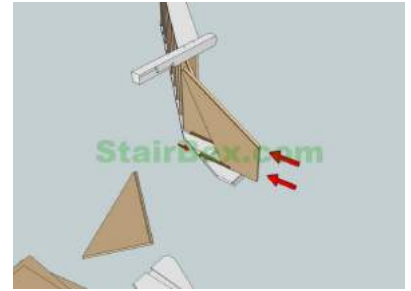

Fitting a mid winder

STEP #1

Follow the newel post fitting guide and fix the newel post to the longer of the 2 stair runs (it doesn't matter if its the upper or lower run). Now locate the first winder step which follows on from the straight run of steps, slide the winder into the wall stringer and newel post housing until the nosing is fully forward within the housing, the winder should fit perfectly in the housing with the back of the tread in line with the above riser trenching **do not trim or modify** any treads, these are cut accurately on a CNC machine, if it doesn't fit you may have the tread in the wrong place. If you have a problem, please call us.

Once you are happy the winder fits into its housing, apply a bead of glue to the newel post housing and to one of the larger (approx 300mm long) winder wedges and drive it into the trenching under the tread using a hammer, ensure the winder tread remains fully seated within the stringer housing (it may sit 1-2mm shy from the bottom of the newel post housing, you must ensure the newel post remains at 90° to the tread!). Next, use a screw secure the newel post end of the winder tread, you will need to drill and pilot drill where appropriate.

STEP #2

Slide the next winder (kite shaped) into the stringer (ensure you have the correct one as they will be different), ensure the tread lines up with the riser housing. Now dry fit the next staircase run into both the newel and string mortice slot to ensure the corner tread fits into this adjacent stringer, using a square make sure the stringers are 90° to each other. Now you are happy with how the tread fits we can secure it into place.

Glue both the newel post tenon and stringer tenon into their mortice slots, you can screw through the back of the upper stringer to hold this in place. Dowels will secure the stringer into the newel post.

Using the same method as before fix the final winder into place, the next step is fitting your risers.

Fitting a 6 winder

STEP #1

Follow the newel post fitting guide and fix the newel post to the longer of the 2 stair runs (it doesn't matter if its the upper or lower run). Now locate the first winder step which follows on from the straight run of steps, slide the winder into the wall stringer and newel post housing until the nosing is fully forward within the housing, the winder should fit perfectly in the housing with the back of the tread in line with the above riser trenching **do not trim or modify** any treads, these are cut accurately on a CNC machine, if it doesn't fit you may have the tread in the wrong place. If you have a problem, please call us.

Once you are happy the winder fits into its housing, apply a bead of glue to the newel post housing and to one of the larger (approx 300mm long) winder wedges and drive it into the trenching under the tread using a hammer, ensure the winder tread remains fully seated within the stringer housing (it may sit 1-2mm shy from the bottom of the newel post housing, you must ensure the newel post remains at 90° to the tread!). Next, use a screw secure the newel post end of the winder tread, you will need to drill and pilot drill where appropriate.

STEP #2

Slide the next winder (kite shaped) fully into the stringer (ensure you have the correct one as they will be different), ensure the tread lines up with the riser housing. Slot the loose stringer into place to ensure the corner tread fits into this adjacent stringer, using a square make sure the stringers are 90° to each other. Now you are happy with how the tread fits we can secure it into place.

Glue the stringer tenon into the mortice slot, you can screw through the back of the upper stringer to hold this in place.

Using the same method as before fixing the next 4 winder treads, the next step is fitting your risers.

Fitting your risers

This stage is very important, and if done correctly your staircase should be forever squeak free! Dry fit each riser around the newel posts, trimming where required. Be aware longer risers are for the kite winders.

Once you are happy the riser fits, run a small bead of glue (we recommend PU woodweld or similar) within the newel housing and along the back of the tread where the riser will be screwed. Beware not to over glue this joint, especially if the flight is not being carpeted as the glue can be difficult to remove from the face of your staircase - its best to run the bead of glue towards the under edge of the stair.

You are now ready to screw the riser to the tread, if your treads and risers are MDF we recommend 40mm screws, on timber 30mm should be ample to fix a 10mm riser. Use 3-4 screws in the pre-drilled holes, be careful not to overtighten or let the screws spin. If screwing into a hardwood tread you will need to drill a pilot hole approximately 2-3mm in diameter. You can also use 1-2 screws to secure the riser into the newel post housing.

The next step is to glue the angle blocks in place with generous amounts of glue, it is very important that these are fixed properly and the glue is allowed to set before use.

2.6.5 Balustrade

Other than at the two bottom steps, a barrier is required to protect users of the stair from falling. This is often provided by a balustrade formed by individual balusters or spindles. So as to provide the necessary protection it is important that the balustrade is fixed securely. Once the stair has been fully assembled and secured in place the balustrade can be fitted.

StairBox staircases usually have the spindles pre-cut ready to be fitted. You will however have to cut the infill to suit the required spindle spacing.

StairBox staircases have the the baserail (string capping) pre-cut to fit tightly between the newels with its ends angled to suit the pitch of the flight. The string capping should be screw fixed to the string starting 50 mm from each end and then at no more than 450 mm centres.

Figure 10 – Newel, balusters, handrail etc.

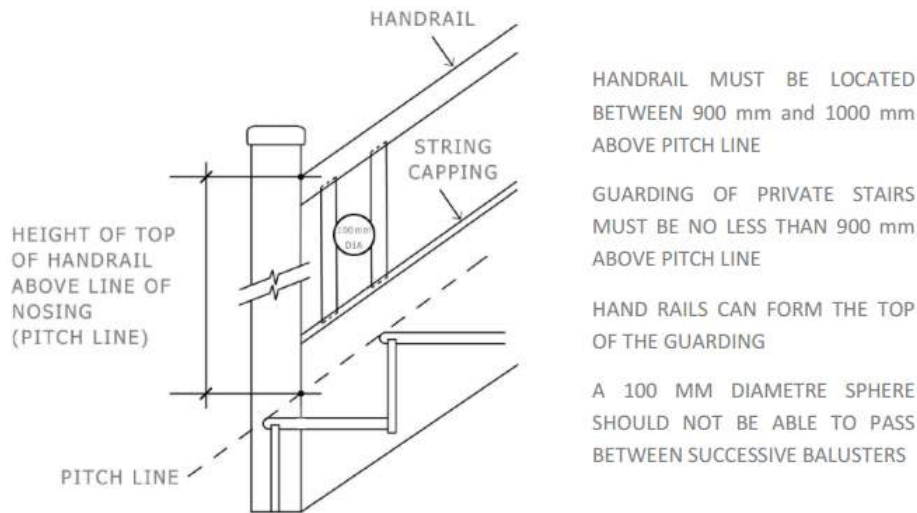

The infill pieces will fill the grooves in the handrail and string capping in between the balusters. They should be cut so that the balusters are evenly spaced and so that no part of the gap between two adjacent balusters would allow a 100 mm diameter sphere to pass through; pay particular attention to turned balusters. It is not necessary for the spacing at the top and bottom newel to be the same as the rest of the balustrade, so, while the spacing between other balusters should be consistent, any adjustments can be made by altering the spacing at the newel. Each baluster should be fixed by gluing and pinning on both the upper and lower faces. The infill pieces should also be glued and pinned.

It's All in The Badge

The BWF Stair Scheme is the only accreditation and certification scheme of its kind in the UK. Ranging from domestic, common and fire protected common stairs, the standard expected of the manufacturers for their stairs is extremely high to ensure quality and safety.



All companies within the scheme are regularly audited to ensure their products and their production meet these high standards. The new third-party certification for fire protected common stairs, supported by the Loss Prevention Certification Board (LPCB) is opening up new markets for timber stairs.

The scheme is managed by the BWF, and includes manufacturers, as well as approved suppliers, who play an important part in maintaining these high standards.

Whilst the BWF Stair Scheme does not accredit installation, guidance is available on the installation of staircases.

© 2014 British Woodworking Federation www.bwf.org.uk

Note: Whilst every effort has been made to ensure the accuracy of advice given, the BWF and StairBox cannot accept liability for loss or damage arising from the use of the information supplied in this publication.